

ISUZU
ELF
NMR81 SHD

**UNTUNG
MELESAT
DENGAN
TRUK
HEBAT**



SPESIFIKASI TEKNIS

DIMENSI / DIMENSION		NMR 81T SHD
Panjang / Overall Length [DAL]	mm	6,000
Lebar / Overall Width [OW]	mm	1,990
Tinggi / Overall Height [OH]	mm	2,310
Jarak Sumbu / Wheelbase [WB]	mm	3,360
Julur Depan / Front Overhang [FOH]	mm	1,110
Julur Belakang / Rear Overhang [ROH]	mm	1,530
Jarak Terendah ke Tanah / Minimum Clearance [HH]	mm	200
Jejak Depan / Front Tread [AW]	mm	1,475
Jejak Belakang / Rear Tread [CW]	mm	1,495

MESIN / ENGINE		
Model		4HL1-TCS
Tipe / Type		In-line 4 Cylinders, SOHC, Direct Injection Diesel, Commonrail
Diameter x Langkah / Bore x Stroke	mm	115 X 115
Isi Silinder / Piston Displacement	cc	4,778
Tenaga Maksimum / Maximum Power	PS/rpm	150 / 2,600
Torsi Maksimum / Maximum Torque	Kgm/rpm	41 / 1,400 - 2,600

TRANSMISI / TRANSMISSION		
Model		MY6S
Perbandingan Gigi / Gear Ratio	1st	5,979
	2nd	3,434
	3rd	1,862
	4th	1,297
	5th	1,000
	6th	0,759
	Rev	5,701
Perbandingan Gigi Terakhir / Final Gear Ratio		5,857

BERAT / WEIGHT		
Berat Kosong Kendaraan / Curb Weight	kg	2,544
Berat Total Kendaraan / Gross Vehicle Weight [GVW]	kg	8,250

REM / BRAKE	NMR 81T SHD
Rem Kaki / Service Brake	Duo servo, floating lever single anchor
Rem Tangan / Hand Brake	Hydraulic, multiple channels with vacuum booster
Sistem Penggeraman Gas Buang/ Exhaust Brake	Ada

GARDAN / AXLE	
Depan / Front	Reverse Elliot I-beam type
Belakang / Rear	Full floating type

RODA / TYRE	
Ban Depan / Front Tyre	Single, 7,50-16-14PR
Ban Belakang / Rear Tyre	Double, 7,50-16-14PR
Velg / Disc Wheel Size	16 X 6.00

SUSPENSI / SUSPENSION	
Depan / Front	Rigid suspension with multi leaf spring
Belakang / Rear	

LAIN-LAIN / OTHERS		
Kapasitas Tangki / Fuel Tank Capacity	ltr	100
Radius Putar Minimum / Minimum Turning Radius	m	7,1
Daya Tanjak Maksimum / Maximum Gradeability	%	43
Kecepatan Maksimum / Maximum Speed	km/h	104
Aki / Accu	V-Ah	24 - 60
Alternator	V-A	24 - 60
Power Steering		Ada
Tilt & Telescopic Steering		Ada
Kamera Mundur / Reverse Parking Camera		Ada
DVD, CD, MP3, USB, Aux In, Radio		Ada
Kabin Jungkit / Tilt Cabin		Ada
Retractable Seat Belt		Ada

* Untuk meningkatkan mutu dan penyesuaian dengan perkembangan teknologi, spesifikasi dapat berubah sewaktu-waktu tanpa pemberitahuan.
** Ilustrasi merupakan contoh sebagian aplikasi di lapangan.

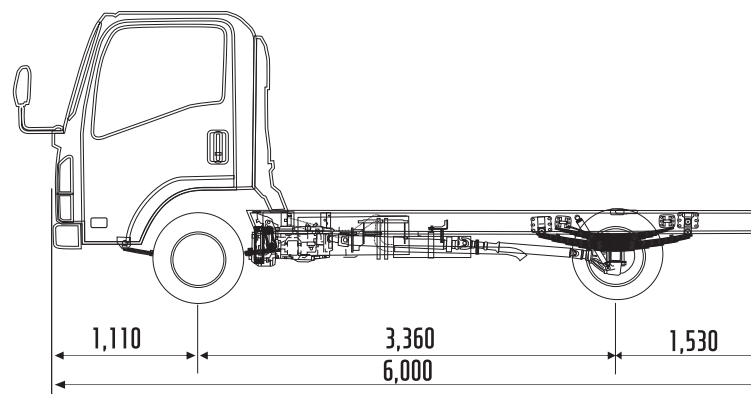
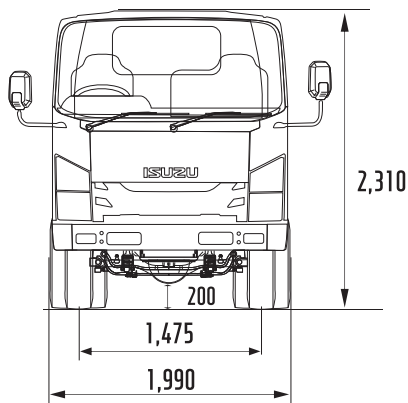

Contoh Aplikasi

■ Aplikasi Bak Besi

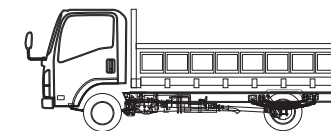

■ Aplikasi Bak Kayu

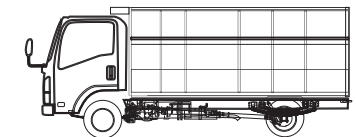

■ Aplikasi Dump

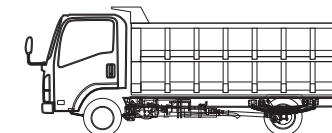

Agen Pemegang Merek & Distributor :

PT ISUZU ASTRA MOTOR INDONESIA

ISUZU
1 x 24 JAM
BESOR TERSEJUK ATAU GRATIS*

ISUZU
FIELD ADVISOR

ISUZU
BIB
BENCAR BANGUN BAHAN

ISUZU
LAYANAN KONSUMEN
Phone: 0807 120 700 0845 0800 120 1200
email: help@isuzuastria.com Service Unit 0819421 00185

Facebook Instagram Twitter @IsuzuID YouTube IsuzuID www.isuzu-astria.com