

**ISUZU BERPENGALAMAN DENGAN
MESIN COMMON RAIL SEJAK 2011**

ISUZU
ELF
NLRB / NLRBL

**IRIT MAKSIMAL,
MUAT PENUMPANG
OPTIMAL**



**euro4
ready**

*Gambar pada brosur ini hanya ilustrasi, mungkin ada perbedaan dengan aktual kendaraan
**Mesin common rail pada Isuzu Giga sejak tahun 2011

REAL PARTNER. REAL JOURNEY.

SPESIFIKASITEKNIS

SPESIFIKASI		NLR B	NLR B L
DIMENSI / DIMENSION			
Panjang / Overall Length [OAL]	mm	4,870	6,170
Lebar / Overall Width [OW]	mm	1,835	1,835
Tinggi / Overall Height [OH]	mm	2,165	2,235
Jarak Sumbu / Wheelbase [WB]	mm	2,490	3,360
Julur Depan / Front Overhang [FOH]	mm	1,110	1,110
Julur Belakang / Rear Overhang [ROH]	mm	1,270	1,700
Jarak Terendah ke Tanah / Minimum Clearance [HH]	mm	200	190
Jejak Depan / Front Tread [AW]	mm	1,475	1,475
Jejak Belakang / Rear Tread [CW]	mm	1,395	1,395
Kapasitas Penumpang / Passenger Capacity		15 + 1 (Driver)	19 + 1 (Driver)
MESIN / ENGINE			
Model		4JJ1-TCC	
Tipe / Type		Direct Injection, Commonrail, DOHC, 4 Cylinder with VGS Turbo Intercooler	
Sistem Kontrol Emisi		EURO4 with EGR & DOC	
Diameter x Langkah / Bore x Stroke	mm	95.4 X 104.9	
Isi Silinder / Piston Displacement	cc	2,999	
Tenaga Maksimum / Maximum Power	PS/rpm	120 / 2,600	
Torsi Maksimum / Maximum Torque	Kgm/rpm	36 / 1,500 - 2,600	
TRANSMISI / TRANSMISSION			
Model		MYY6S	
Perbandingan Gigi / Gear Ratio	1st	5.979	
	2nd	3.434	
	3rd	1.862	
	4th	1.297	
	5th	1.000	
	6th	0.759	
	Rev	5.701	
Perbandingan Gigi Terakhir / Final Gear Ratio		4.300	

SPESIFIKASI		NLR B	NLR B L
BERAT / WEIGHT			
Berat Kosong Kendaraan / Curb Weight	kg	1,754	1,892
Berat Total Kendaraan / Gross Vehicle Weight [GVW]	kg	5,100	
Kapasitas Gardan Depan / Capacity Front Axle	kg	2,460	
Kapasitas Gardan Belakang / Capacity Rear Axle	kg	2,640	
REM / BRAKE			
Tipe/Type		Hydraulic	
Rem Kaki / Service Brake		Hydraulic saluran ganda dengan vacum booster	
Rem Tangan / Hand Brake		Expanding pada transmisi belakang	
Sistem Pengereman Gas Buang / Exhaust Brake		Exhaust brake, tuas berada di stir	
RODA / TYRE			
Ukuran Ban		225/75/R16	
Ukuran Velg		16 X 7.00	
SUSPENSI / SUSPENSION			
Depan / Front		Semi elliptical laminated leaf spring dengan shock absorber berdaya ganda	
Belakang / Rear			
LAIN-LAIN / OTHERS			
Kapasitas Tangki / Fuel Tank Capacity	ltr	75	100
Radius Putar Minimum / Minimum Turning Radius	m	5.7	7.4
Daya Tanjak Maksimum / Maximum Gradeability	%	49	
Kecepatan Maksimum / Maximum Speed	km/h	116	
Aki / Accu	V-Ah	2 X 12 V - 65 Ah	
Alternator	V-A	24 - 50	
Kamera Mundur / Reverse Parking Camera		Ada	
Audio Head Unit		Ada	
USB Charging System		Ada	
Fan Blower		Ada	
Garansi / Warranty		3 Tahun / 100,000 km	

* Untuk meningkatkan mutu dan penyesuaian dengan perkembangan teknologi, spesifikasi dapat berubah sewaktu-waktu tanpa pemberitahuan.
 ** Ilustrasi merupakan contoh sebagian aplikasi di lapangan.

DIMENSI

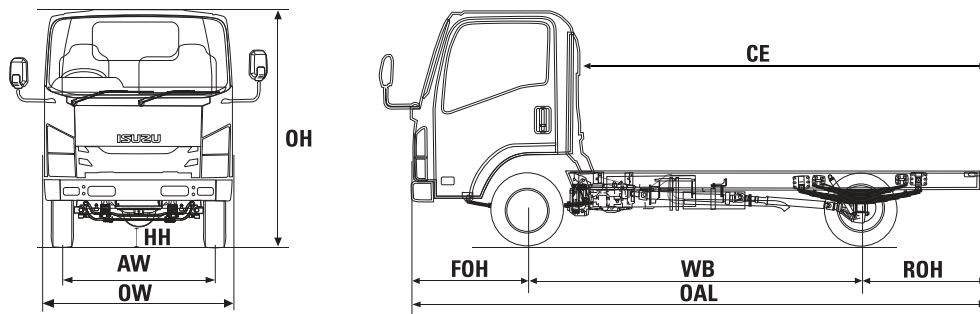

APLIKASI

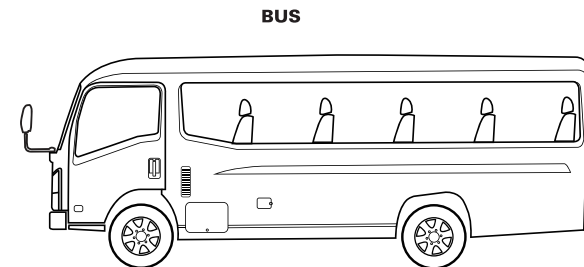

SCAN INI
UNTUK
INFORMASI
LEBIH LANJUT